



SEMI F74-1102

TEST METHOD FOR THE PERFORMANCE AND EVALUATION OF METAL SEALS USED IN GAS DELIVERY SYSTEMS

This test method was technically approved by the Global Gases Committee and is the direct responsibility of the North American Gases Committee. Current edition approved by the North American Regional Standards Committee on August 29, 2002. Initially available at www.semi.org September 2002; to be published November 2002.

1 Purpose

1.1 This document is a test method for evaluating metal seals used in gas delivery systems. It covers both surface-mounted gas systems and conventional metal face seal fitting systems.

2 Scope

2.1 The test methods apply to the connection seals used in conventional tubing type gas systems and between modules and components to the substrates used in surface-mounted gas systems.

2.2 This standard does not purport to address safety issues, if any, associated with its use. It is the responsibility of the users of this standard to establish appropriate safety and health practices and determine the applicability of regulatory limitations prior to use.

3 Limitations

3.1 This test method does not provide detailed information sufficient for conducting the procedures. It is the responsibility of the user to procure a copy of the referenced test procedures from the issuing organizations.

3.2 The test methods mentioned in this document are destructive in some cases. Therefore, the sequence of tests should be carefully planned with the understanding that several specimens are required to complete the battery of all applicable tests without invalidating later tests. This requirement of several specimens is in addition to the iteration normally required under good statistical practices.

3.3 All components must meet quality requirements (dimensional, sealing-surface finish, etc.), as established and controlled by manufacturers prior to testing.

3.4 Surface-mounted connection methods and system design will affect exterior load testing (i.e., vibration, shock, etc.).

3.5 Seals must be manufactured and packaged for Class 100-type applications.

3.6 Care should be exercised in handling seals to maintain manufacturer's specifications.

4 Referenced Standards

4.1 SEMI Standards

SEMI E49 — Guide for Standard Performance, Practices, and Sub-Assembly for High Purity Piping Systems and Final Assembly for Semiconductor Manufacturing Equipment

SEMI F1 — Specification for Leak Integrity of High-Purity Gas Piping Systems and Components

4.2 ASME Standards¹

B31.3 — ASME Code for Process Piping

4.3 Military Standard²

MIL-STD-810E — Environmental Test Methods and Engineering Guidelines

4.4 Federal Standard³

Federal Standard 209E — Airborne Particle Cleanliness Classes in Cleanrooms and Clean Zones

NOTE 1: Unless otherwise indicated, all documents cited shall be the latest published versions.

5 Terminology

5.1 Abbreviations and Acronyms

5.1.1 *atm* — atmosphere

5.1.2 *cc* — cubic centimeter

5.1.3 *ft-lbs* — foot-pounds (force)

5.1.4 *kPa* — kiloPascal

5.1.5 *mPa* — megaPascal

1 American Society of Mechanical Engineers, 3 Park Ave., New York, NY 10016-5980, 212-591-7722, telex: 710-591-5627, fax: 212-591-7674.

2 Available through the Naval Publications and Forms Center, 5801 Tabor Avenue, Philadelphia, PA 19120-5099, USA. Telephone: 215.697.3321

3 Federal Standard, c/o U.S. Government Printing Office, Washington DC 20402

5.1.6 *N* — Newton

5.1.7 *Nm* — Newton meters

5.1.8 *Pa* — Pascal

5.1.9 *psig* — pounds per square inch (gauge pressure)

5.2 Definitions

5.2.1 *cap block* — a seal-specific component fixture specially made to mate with a respective seal-system substrate block for testing purposes.

5.2.2 *Class 100* — a cleanroom designation defined by *Federal Standard 209E* which designates that each cubic foot (SI equivalent cubic meter) of air can have no more than 100 particles at a size of 0.5 μ m or larger.

5.2.3 *component* — an individual piece or a complete assembly of individual pieces capable of being joined with other pieces or components.

5.2.4 *connector block* — a seal-specific substrate block fixture made to mate with a respective seal-system cap or flow-through block for testing purposes.

5.2.5 *Conventional System* — a gas system utilizing tubing and standard face seal type weld fittings joined together using orbital TIG welding.

5.2.6 *design pressure* — of a system or subsystem, the pressure at the most severe condition of internal and external pressure for which it is appropriate (as defined by the designer) to use the system or subsystem.

5.2.7 *dummy* — a term meant to denote an imitation of a real or original object. In this case, the original object would be a modular surface mount valve.

5.2.8 *finger-tight* — where a particular joining apparatus (seal-system) is compressed/torqued to the point where one would need a tool of some sort to apply further force.

5.2.9 *fixture* — a device specially designed and manufactured for a particular seal-system and performance test. Sample performance testing fixtures can be seen in Appendix 1.

5.2.10 *flow-through* — a term used to signify that the configuration of a given fixture or substrate must allow for gas to pass through from an inlet interface point to an outlet interface point. A flow-through device allows one to make flow calculations and obtain particle counts.

5.2.11 *hydrostatic leak* — a leak or leak test performed by applying isostatic pressure via some sort of liquid phase media (i.e. hydraulic fluid, water).

5.2.12 *inboard leak rate* — leakage rate expressed in Pa.m³/s (*atm cc/sec*) from outside to inside occurring

when an internal pressure is less than the external pressure acting on the component or system. Inboard leakage is typically determined by introducing a tracer gas around the exterior of the piping system or component under test.

5.2.13 *leak* — a path (or paths) in a sealed system that will pass tracer gas when a pressure differential or diffusion path exists. There are two leak mechanisms: a mechanical passage and a material through which a gas can diffuse or permeate. A leak may have both mechanisms operating in parallel.

5.2.14 *outboard leak rate* — leakage rate expressed in Pa.m³/s (*atm-cc/sec*) occurring from inside to outside when an internal pressure is greater than the external pressure acting on the component or system. Outboard leakage is typically determined by introducing a tracer gas into the interior of the piping system or component under test.

5.2.15 *seal* — a device (i.e. gasket, O-ring, etc.) that joins two elements or systems so as to prevent leakage.

5.2.16 *sealing system* — a system that consists of two mating surfaces (e.g. component/ substrate), seal(s), fasteners (screws), and any necessary hardware (e.g. seal keepers).

5.2.17 *substrate* — the block consisting of machined passage(s) which define the flow path of a gas. Gas control components are attached to certain areas on the substrate block with gas seals at the interface.

5.2.18 *Surface-mounted Gas Systems* — term used to denote the gas distribution technology where *surface-mounted* gas components (e.g. filters, regulators, MFC's, and valves) are mounted onto a flat substrate which defines the flow path of the gas. The sealing system will commonly be located at various locations within the interface plane between component and substrate.

5.2.19 *test pressure* — the pressure at which a sealing system is hydrostatically tested. The test pressure is commonly defined as 1.5 times the maximum design pressure.

5.2.20 *vibration table* — a mechanized table that will vibrate with a controlled frequency, direction(s), and amplitude. It is commonly used for vibration testing.

6 Significance and Use

6.1 The following tests shall be performed on seals which have been assembled into a test fixture similar to the fixtures described in the appendix. These fixtures are not intended to duplicate an entire gas system, but are established to evaluate seals only.

6.2 All sealing surfaces and fastening systems shall be manufactured in strict accordance with seal manufacturer's instructions and requirements. In addition, seals shall be handled and installed per seal manufacturer's instructions.

7 Universal Test Methods

The tests listed in this section shall be performed as a minimum for all sealing systems. This section defines tests that pertain to both surface-mounted and conventional gas sealing systems.

NOTE 2: Refer to Appendix 1 for conventional and surface-mount test fixtures.

7.1 Sample configuration shall be defined prior to testing for each section and noted with test results.

7.2 Helium Leak Tests, Operating and Proof Pressure

7.2.1 Inboard Helium Leak Test

7.2.1.1 Testing shall be conducted per test methods and procedures outlined in SEMI F1 test methods at room temperature.

7.2.1.2 Sample quantity: 20

7.2.2 Outboard Helium Leak Test and Proof Test

7.2.2.1 Testing shall be conducted per procedures outlined in SEMI F1 method 2 and the following paragraphs.

7.2.2.2 Assemble the sample per manufacturer's instructions.

7.2.2.3 Place the test assembly in a bell jar and evacuate with the leak detector.

NOTE 3: The bell jar must be equipped with over pressure protection in the event of failure.

7.2.2.4 Gradually increase pressure to manufacturer's maximum rated working pressure and hold for two minutes. If leakage beyond acceptance requirements occurs at anytime during testing, note the pressure and leak rate and discontinue testing of that sample.

7.2.2.5 Continue increasing pressure to 1.5× the manufacturer's maximum rated working pressure and hold for five minutes. Reduce the pressure back to the maximum rated working pressure and note the leak rate at this pressure.

7.2.2.6 Sample quantity: 4

NOTE 4: Outboard leak testing should be completed on only the referenced 4 samples. All subsequent leak testing required in conjunction with other testing should be inboard only.

7.3 Hydraulic Burst Test

7.3.1 Assemble the test sample per manufacturer's instructions.

7.3.2 Attach the sample to a hydraulic pressure source using qualified high pressure connections.

7.3.3 Samples shall be tested within an enclosure suitably designed to protect personnel from failure.

7.3.4 Test medium shall be water or hydraulic fluid.

7.3.5 Gradually increase pressure to maximum rated working pressure and hold for one minute.

7.3.6 Gradually increase pressure until failure, or 4x manufacturer's rated working pressure is reached.

7.3.7 Sample quantity: 4

7.4 Temperature Cycle Test Method

7.4.1 Perform an initial inboard leak test on the sealing system in accordance with Section 7.2.1.

7.4.2 Install the plumbing and test sample apparatus with test sample(s) installed into a temperature controlled chamber. Attach a thermocouple to the exterior of the apparatus adjacent to the test sample.

7.4.3 Heat the chamber until the temperature indicated by the thermocouple is $100 + 10/-0^{\circ}\text{C}$. Hold 10 minutes after the temperature stabilizes, then perform an inboard leak test in accordance with Section 7.2.1.

7.4.4 Cool the chamber until the temperature indicated by the thermocouple is $-10 + 0/-10^{\circ}\text{C}$ and perform an inboard leak in accordance with Section 7.2.1 while at temperature.

NOTE 5: If the seal is intended for outdoor service, refrigerate the test apparatus to $-54 + 0/-10^{\circ}\text{C}$.

7.4.5 Repeat Sections 7.4.1 through Section 7.4.4 for a total of 5 cycles.

7.4.6 Sample quantity: 3 samples

7.5 Repeatability of Sealing System

7.5.1 Photograph mating surfaces at 10× magnification.

7.5.2 Perform initial inboard leak test on sealing system per Section 7.2.1.

7.5.3 A sequence of 10 make and remake cycles shall be performed on the same sealing system.

NOTE 6: Replace seal after each cycle if recommended by manufacturer.

7.5.4 Perform internal leak test per Section 7.2.1 after each make and remake cycle.

7.5.5 Record all visible damage of the mating surfaces in the form of scratches, burrs, or other particles photographed after the different intervals at 10x magnification.

7.5.6 Repeat Section 7.5.2 through Section 7.5.4 three additional times using a new set of mating surfaces each time.

NOTE 7: Replace seal after each cycle if recommended by manufacturer.

7.6 Shock and Vibration Test Method

7.6.1 This test is designed to evaluate the effects of random accelerations and sustained vibrations during shipment of gas systems.

7.6.2 Install seals and assemble per manufacturer's instructions.

7.6.3 Perform inboard leak test per Section 7.2.1.

7.6.4 Conduct shock test per MIL-STD-810E, Method 516.4, Section I-3.1a), procedure I (functional shock), using terminal-peak saw-tooth shock pulse for ground equipment operation test.

7.6.5 Perform inboard leak test per Section 7.2.1.

7.6.6 Conduct vibration test per MIL-STD-810E, Method 514.4, procedure 1 (basic transportation). Test duration: 1 hour per 1,609 km (1000 miles) of transportation in each directional axis.

7.6.7 Perform inboard leak test per Section 7.2.1.

7.6.8 Sample quantity: 3

7.7 Seal Preload Safety Factor

7.7.1 This test evaluates the effects of under-tightening and over-tightening a seal connection.

7.7.2 Install seal and assemble to 80% of the manufacturer's sealing load (e.g. torque).

7.7.3 Perform inboard leak test per Section 7.2.1.

7.7.4 Disassemble and repeat using a new seal for each test.

7.7.5 Sample quantity: 3

7.7.6 Using the same components, install a new seal and assemble to 120% of the manufacturer's sealing load.

7.7.7 Perform inboard leak test per Section 7.2.1. and note any form of deformation or damage to the seal connection. Replace connection for subsequent tests if connection is damaged.

7.7.8 Disassemble and repeat using a new seal for each test.

7.7.9 Sample quantity: 3

7.8 Torsion Test

7.8.1 This test is designed to measure whether the sealing system can maintain leak integrity when torque is applied to an adjacent component or position.

7.8.2 Install seal and assemble per manufacturer's instructions.

7.8.3 Place a stationary digital torque wrench on the adjacent component position to measure the torque applied as make up takes place. Location of placement is seen in Figure A1-1.

7.8.4 Test per Section 7.2.1.

7.8.5 Rotate the adjacent component in a clockwise direction until 57.6 cm-kgf (50 in-lbf; 5.649 Nm) torque is measured on the stationary torque wrench.

7.8.6 Test per Section 7.2.1.

7.8.7 Rotate the adjacent component in a counterclockwise direction until 57.6 cm-kgf (50 in-lbf; 5.649 Nm) torque is measured on the stationary torque wrench.

7.8.8 Test per Section 7.2.1.

7.8.9 Repeat 7.8.5 through 7.8.8 with 115.2 cm-kgf (100 in-lbf; 66.355 Nm) torque.

7.8.10 Sample quantity: 3

7.9 Surface Defect Test

7.9.1 This test method is for evaluating the robustness of sealing technologies for gas delivery systems used in semiconductor manufacturing against surface defects which could occur during normal handling in the field.

7.9.2 A material testing machine is used to make a defect on the surface. In place of a pyramid-shaped indenter for hardness measurement, a wedged shaped indenter, specifically designed for this test, is installed in the adjustable-load hardness measurement equipment shown in Figure 1 and is used to make a surface defect on test sample.

7.9.3 The indenter shall meet the dimensional requirement shown in Figure 2. The indenter shall have a minimum hardness of 500 Vickers.

7.9.4 This test defaces only the seal face of the component, and determines the size of the surface defect as well as the corresponding leak. In this way, the degree of weakness of the component's seal face, as well as the extent to which the leak can be stopped depending on defect size, can be determined, making it possible to evaluate the robustness of the sealing technology being tested.

7.9.5 Equipment shown in Figure 1 and Figure 2 is used to make a defect on the surface of the seal face of the component or substrate.

7.9.6 Load levels are 2, 4, 6, 8 kgf, (19.61, 39.23, 58.84, 78.45 N) and add 2 kgf (19.61 N) incrementally until leaking occurs. The test sample should be tightened according to the manufacturer's installation manual.

7.9.7 A leak test is performed on the sample according to the procedure in SEMI F1. As this document is a test method, not a specification, only the procedure in SEMI F1 applies.

7.9.8 Correlation between the load and the leak is determined.

7.9.9 Surface defect size (depth and width) is measured using surface roughness measuring equipment for reference.

7.10 *Particle Cleanliness After Seal Make-up*

7.10.1 The purpose of this test is to verify the particles generated during a sealing-system compression cycle. This test involves testing for particles in situ, while compressing a sealing system.

7.10.2 Test per SEMASPEC 90120390B-STD. Use a flow-through testing apparatus that is seal-specifically designed for use in this test, in place of a valve.

7.10.3 Testing must be performed in a Class 100 (or better) environment in order to obtain low background counts before the seals are tightened to the substrate.

7.10.4 Follow test protocol in Test Method for Particle Contribution (see Related Documents) with the exception that a flow-through bypass fixture must be attached "finger-tight" to a test substrate before obtaining a background count.

7.10.5 The testing apparatus with the seals to be tested must be purged with 0.01 μm filtered gas for sufficient time so as to remove all inherent particles present during installation.

7.10.6 Once the lowest possible background count has been generated, the flow-through test device must be tightened to the seal manufacturer's specifications while gathering particle counts from the particle counter. It is recommended that the counts are recorded via a data acquisition device to allow the user to compress the seals while the particles are being recorded.

7.10.7 This test is for comparison purposes only between data generated at a common facility with common test setup.

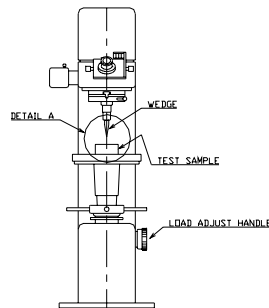

Figure 1
Load Adjustable Hardness Measuring Equipment

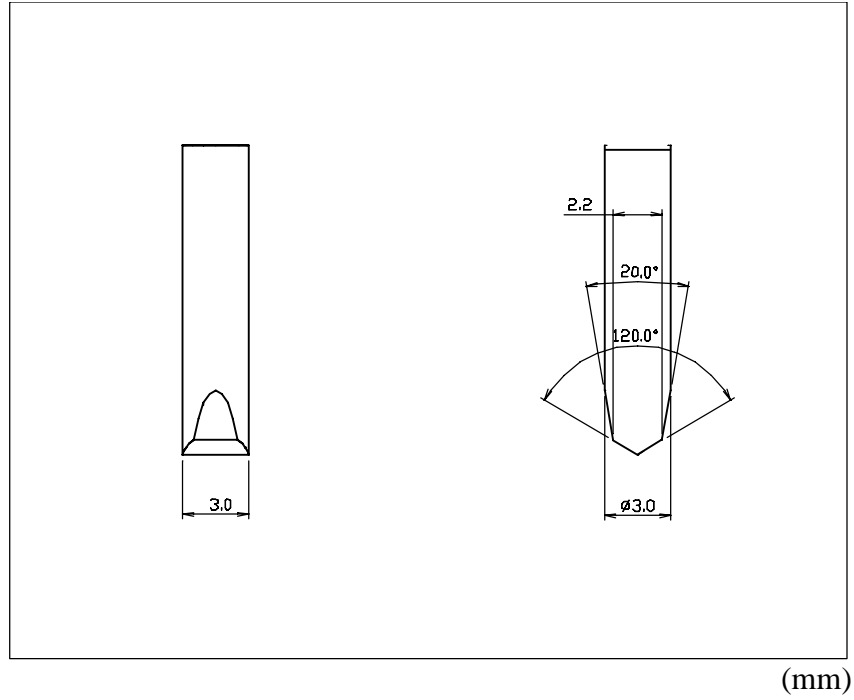

Figure 2
Dimension of the Wedge-Shaped Indenter

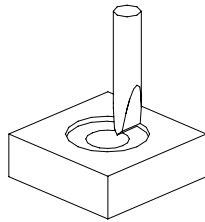

Figure 3
Wedge and Test Sample (Component or Substrate)

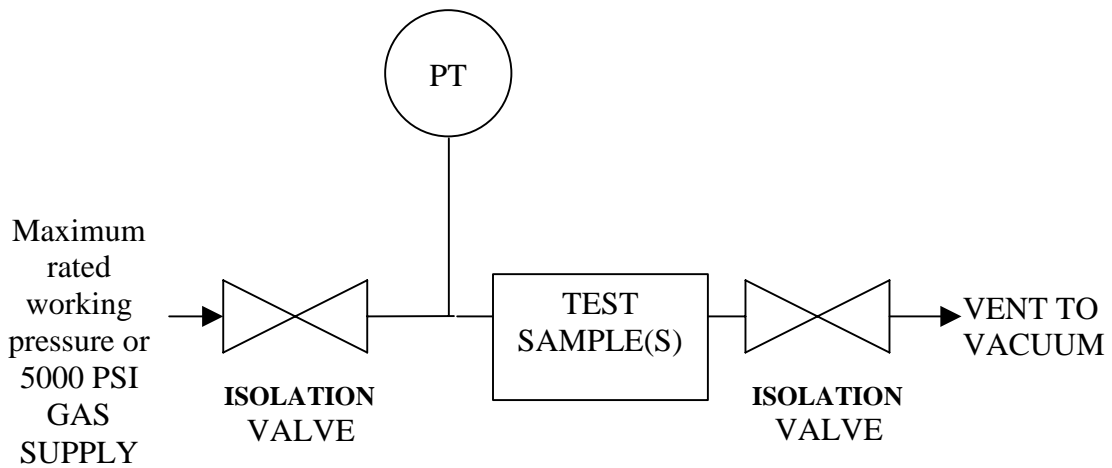

Figure 4
Pressure Cycling Test Rig

7.11 Corrosion Testing

7.11.1 Due to the lack of proven, standardized test methods for quantifying the performance of gas systems in corrosive environments, this document can only reference two applicable test procedures for use to supply qualitative information relating to the performance of gas system metal seals under corrosive serve: SEMASPEC 92071233B-STD and SEMASPEC 97043272A-TR (see Related Documents). It will be the responsibility of the requesting party to define the specific testing and acceptance criteria for this type of evaluation.

7.12 Pressure Cycling Test

7.12.1 Assemble the test sample(s) into the test rig shown in Figure 4 per the manufacturer's instructions.

7.12.2 Cycle the test sample(s) for a total of 250,000 cycles. The following represents one cycle:

7.12.2.1 Apply the manufacturer's maximum rated working pressure +/- 2% or 5000 +/- 100 psig, whichever is less.

7.12.2.2 Maintain pressure for at least 1 second after the transducer indicates that the pressure requirement has been achieved.

7.12.2.3 Vent the pressure to 74.5 KPa or less.

7.12.2.4 Maintain the vacuum for at least 1 second after the transducer indicates that vacuum requirement has been achieved.

7.12.3 Leak test per Section 7.2.1.

7.12.4 Sample quantity: 5

8 Related Documents

8.1 SEMATECH Documents⁴

SEMASPEC 90120390B-STD — Test Method for Particle Contribution

SEMASPEC 97043272A-TR — Accelerated Life Testing of Gas System Performance and Reliability

SEMASPEC 92071233B-STD — Provisional Test Method for Determining the Corrosion Resistance of Mass Flow Controllers (MFCs).

⁴ SEMATECH, 2706 Montopolis Drive, Austin, TX, website: www.sematech.org

APPENDIX 1

NOTE: This appendix is being balloted as an official part of SEMI F74 by full letter ballot procedure, but the recommendation in this appendix are optional and are not required to conform to this standard.

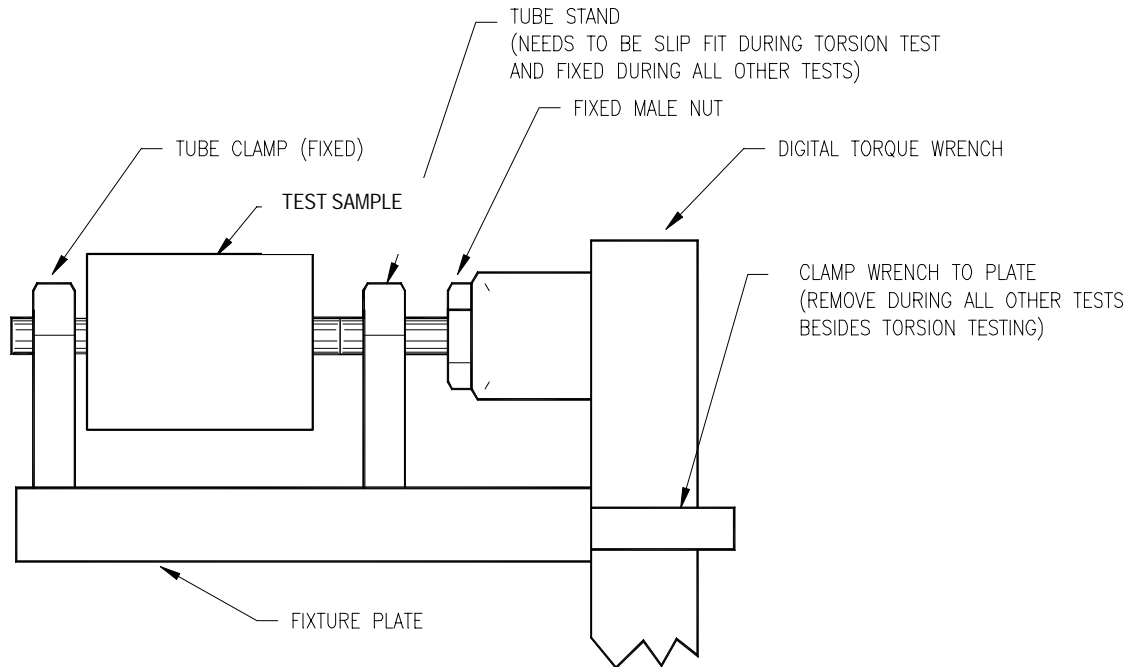
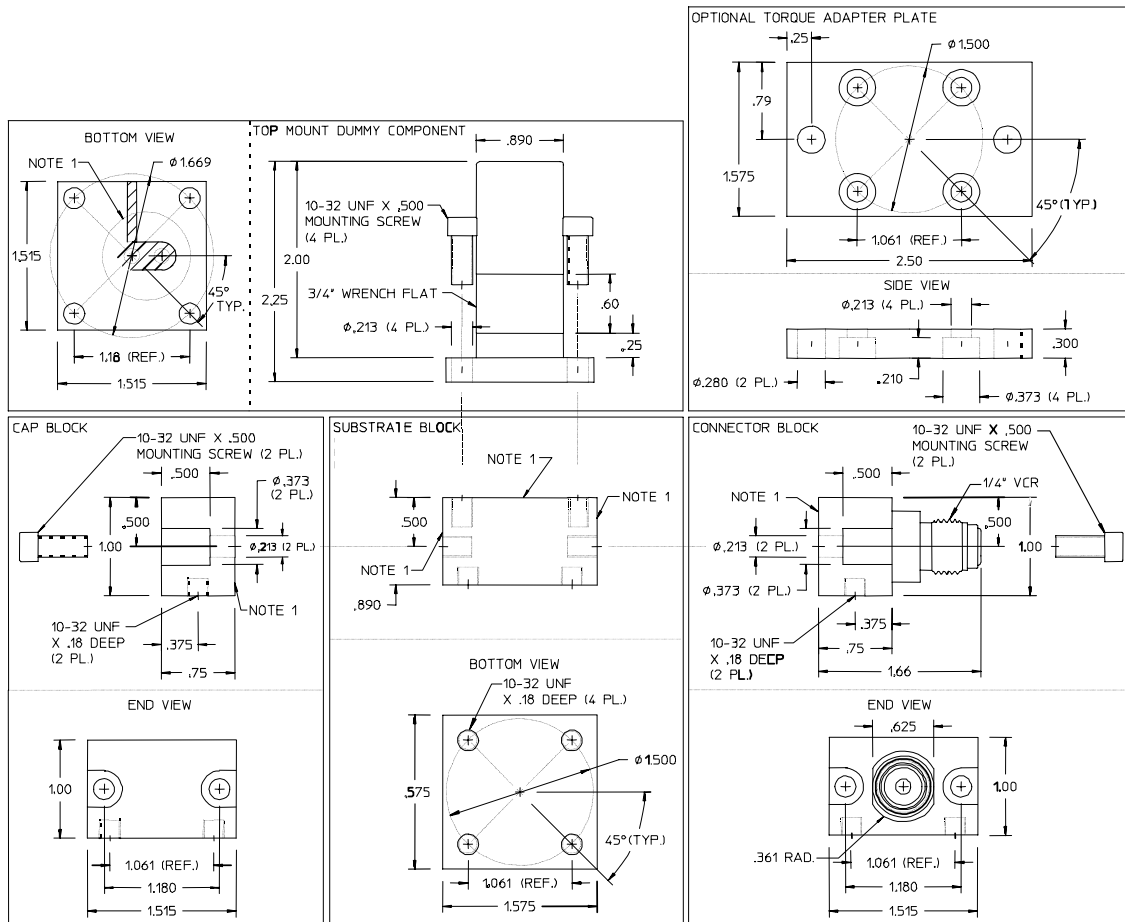

Figure A1-1
Conventional Performance Testing Sample

ASSEMBLY VIEW; VIBRATION/TORQUE TEST FIXTURE



NOTE 1: Leak test port(s) and porting are dependent on seal system/substrate design configuration.

NOTE 2: Material of Construction: 316SS.

NOTE 3: Drawing scale is not specified.

Figure A1-2
Surface-Mount Performance Testing Fixture

NOTICE: SEMI makes no warranties or representations as to the suitability of the standards set forth herein for any particular application. The determination of the suitability of the standard is solely the responsibility of the user. Users are cautioned to refer to manufacture's instructions, product labels, product data sheets, and other relevant literature, respecting any materials or equipment mentioned herein. These standards are subject to change without notice.

By publications of this standard, Semiconductor Equipment and Materials International (SEMI) takes no position respecting the validity of any patent rights or copyrights asserted in connection with any items mentioned in this standard. Users of this standard are expressly advised that determination of any such patent rights or copyrights, and the risk of infringement of such rights are entirely their own responsibility.